

LINCE

USER'S AND INSTALLER'S MANUAL

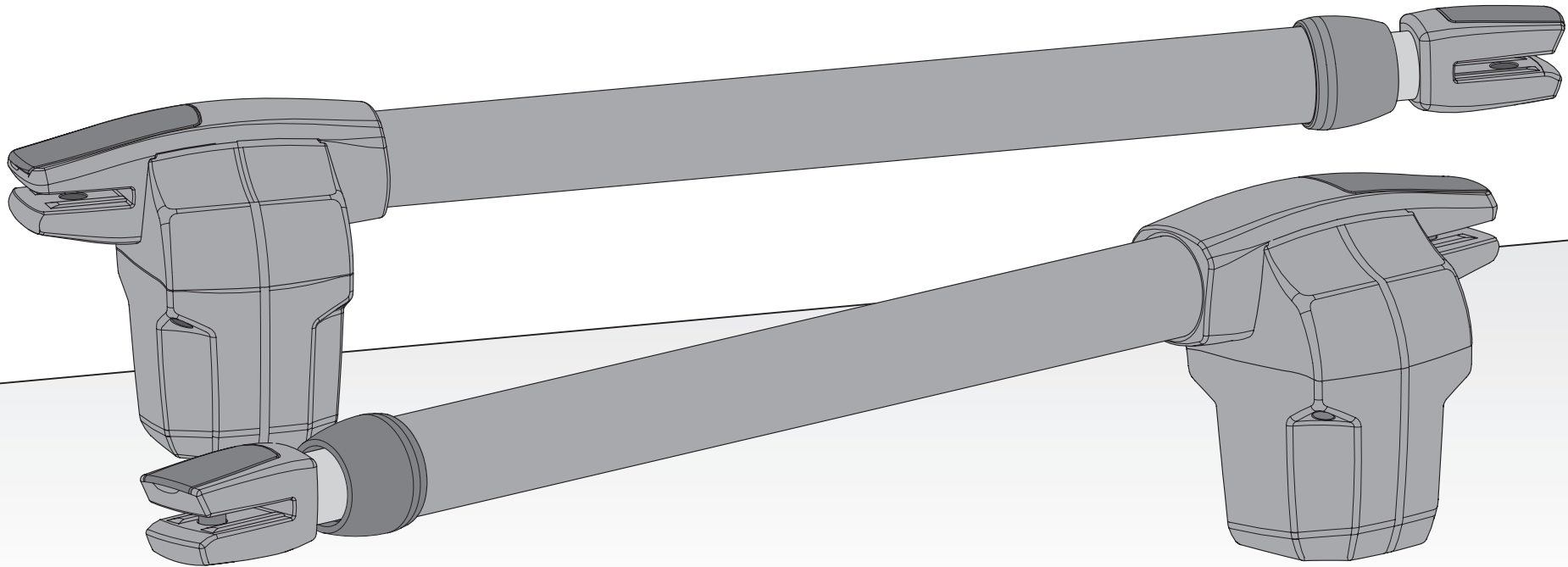

00. CONTENT

INDEX

01. SAFETY INSTRUCTIONS

STANDARDS TO FOLLOW 1B

02. PACKAGE

INSIDE PACKAGE 4A

03. AUTOMATION

CHANGE MOTOR DIRECTION 4B

MANUAL RELEASE 5B

TECHNICAL SPECIFICATIONS 6A

04. INSTALLATION

HEIGHT OF THE SUPPORTS 6B

INTERIOR OPENING INSTALLATION DIMENSIONS 7

EXTERNAL OPENING INSTALLATION DIMENSIONS 8

INSTALLATION STEPS 9A

INSTALLATION MAP 10

05. TROUBLESHOOTING

FINAL CONSUMERS INSTRUCTIONS 11

INSTRUCTIONS FOR SPECIALIZED INSTALLERS 11

06. COMPONENTS TEST







230V/110V MOTOR 12A

24V MOTOR 12B

07. MAINTENANCE

MAINTENANCE 13A

01. SAFETY INSTRUCTIONS

	This product is certified in accordance with European Community (EC) safety standards.
	This product complies with Directive 2011/65/EU of the European Parliament and of the Council, of 8 June 2011, on the restriction of the use of certain hazardous substances in electrical and electronic equipment and with Delegated Directive (EU) 2015/863 from Commission.
	(Applicable in countries with recycling systems). This marking on the product or literature indicates that the product and electronic accessories (eg. Charger, USB cable, electronic material, controls, etc.) should not be disposed of as other household waste at the end of its useful life. To avoid possible harm to the environment or human health resulting from the uncontrolled disposal of waste, separate these items from other types of waste and recycle them responsibly to promote the sustainable reuse of material resources. Home users should contact the dealer where they purchased this product or the National Environment Agency for details on where and how they can take these items for environmentally safe recycling. Business users should contact their vendor and check the terms and conditions of the purchase agreement. This product and its electronic accessories should not be mixed with other commercial waste.
	This marking indicates that batteries should not be discarded like other household waste at the end of their useful life. Batteries must be delivered to selective collection points for recycling.
	The different types of packaging (cardboard, plastic, etc.) must be subject to selective collection for recycling. Separate packaging and recycle it responsibly.
	This marking indicates that the product and electronic accessories (eg. charger, USB cable, electronic material, controls, etc.) are susceptible to electric shock by direct or indirect contact with electricity. Be cautious when handling the product and observe all safety procedures in this manual.

01. SAFETY INSTRUCTIONS

GENERAL WARNINGS

- This manual contains very important safety and usage information. Read all instructions carefully before beginning the installation/usage procedures and keep this manual in a safe place that it can be consulted whenever necessary.
- This product is intended for use only as described in this manual. Any other enforcement or operation that is not mentioned is expressly prohibited, as it may damage the product and put people at risk causing serious injuries.
- This manual is intended firstly for specialized technicians, and does not invalidate the user's responsibility to read the "User Norms" section in order to ensure the correct functioning of the product.
- The installation and repair of this product may be done by qualified and specialized technicians, to assure every procedure are carried out in accordance with applicable rules and norms. Nonprofessional and inexperienced users are expressly prohibited of taking any action, unless explicitly requested by specialized technicians to do so.
- Installations must be frequently inspected for unbalance and the wear signals of the cables, springs, hinges, wheels, supports and other mechanical assembly parts.
- Do not use the product if it is necessary repair or adjustment is required.
- When performing maintenance, cleaning and replacement of parts, the product must be disconnected from power supply. Also including any operation that requires opening the product cover.
- The use, cleaning and maintenance of this product may be carried out by any persons aged eight years old and over and persons whose physical, sensorial or mental capacities are lower, or by persons without any knowledge of the product, provided that these are supervision and instructions given by persons with experienced in terms of usage of the product in a safe manner and who understands the risks and dangers involved.

- Children shouldn't play with the product or opening devices to avoid the motorized door or gate from being triggered involuntarily.
- If the power cable is damaged, it must be replaced by the manufacturer, after-sales service or similarly qualified personnel to avoid danger.
- The device must be disconnected from the electrical network when removing the battery.
- Ensure that blocking is avoided between the actuated part and its fixed parts due to the opening movement of the actuated part.

WARNINGS FOR TECHNICIANS

- Before beginning the installation procedures, make sure that you have all the devices and materials necessary to complete the installation of the product.
- You should note your Protection Index (IP) and operating temperature to ensure that is suitable for the installation site.
- Provide the manual of the product to the user and let them know how to handle it in an emergency.
- If the automatism is installed on a gate with a pedestrian door, a door locking mechanism must be installed while the gate is in motion.
- Do not install the product "upside down" or supported by elements do not support its weight. If necessary, add brackets at strategic points to ensure the safety of the automatism.
- Do not install the product in explosive site.
- Safety devices must protect the possible crushing, cutting, transport and danger areas of the motorized door or gate.
- Verify that the elements to be automated (gates, door, windows, blinds, etc.) are in perfect function, aligned and level. Also verify if the necessary mechanical stops are in the appropriate places.
- The control board must be installed on a safe place of any fluid (rain, moisture, etc.), dust and pests.
- You must route the various electrical cables through protective tubes, to protect them against mechanical exertions, essentially on

01. SAFETY INSTRUCTIONS

the power supply cable. Please note that all the cables must enter the control board from the bottom.

- If the automatism is to be installed at a height of more than 2,5m from the ground or other level of access, the minimum safety and health requirements for the use of work equipment workers at the work of Directive 2009/104/CE of European Parliament and of the Council of 16 September 2009.
- Attach the permanent label for the manual release as close as possible to the release mechanism.
- Disconnect means, such as a switch or circuit breaker on the electrical panel, must be provided on the product's fixed power supply leads in accordance with the installation rules.
- If the product to be installed requires power supply of 230Vac or 110Vac, ensure that connection is to an electrical panel with ground connection.
- The product is only powered by low voltage safety with control board (only at 24V motors).
- Parts/products weighing more than 20 kg must be handled with special care due to the risk of injury. It is recommended to use suitable auxiliary systems for moving or lifting heavy objects.
- Pay special attention to the danger of falling objects or uncontrolled movement of doors/gates during the installation or operation of this product.

WARNINGS FOR USERS

- Keep this manual in a safe place to be consulted whenever necessary.
- If the product has contact with fluids without being prepared, it must immediately disconnect from the power supply to avoid short circuits, and consult a specialized technician.
- Ensure that technician has provided you the product manual and informed you how to handle the product in an emergency.
- If the system requires any repair or modification, unlock the automatism, turn off the power and do not use it until all safety

conditions have been met.

- In the event of tripping of circuits breakers or fuse failure, locate the malfunction and solve it before resetting the circuit breaker or replacing the fuse. If the malfunction is not repairable by consult this manual, contact a technician.
- Keep the operation area of the motorized gate free while the gate in in motion, and do not create strength to the gate movement.
- Do not perform any operation on mechanical elements or hinges if the product is in motion.

RESPONSABILITY

- Supplier disclaims any liability if:
 - Product failure or deformation result from improper installation use or maintenance!
 - Safety norms are not followed in the installation, use and maintenance of the product.
 - Instructions in this manual are not followed.
 - Damaged is caused by unauthorized modifications
 - In these cases, the warranty is voided.

MOTORLINE ELECTROCELOS SA.

Travessa do Sobreiro, nº29
4755-474 Rio Côvo (Santa Eugénia)
Barcelos, Portugal

SYMBOLS LEGEND:



• Important safety notices



• Useful information



• Programming information



• Potentiometer information



• Connectors information



• Buttons information

02. PACKAGE

INSIDE PACKAGE

In the package you will find the following components:

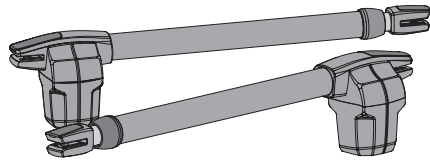

• 02 Motors

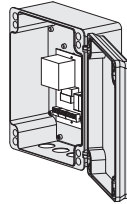

• 01 Control board



• 02 Front supports



• 02 Remote controls

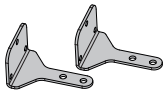

• 02 Rear supports

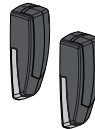

• 01 Photocells set



• 02 Release keys



• 02 Capacitors
[Only available with the 230v
(8µf) and 110v(20µf) models]



• 01 User's manual

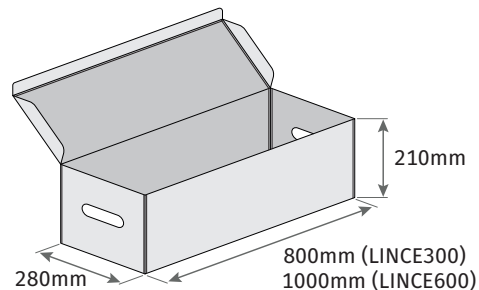

03. AUTOMATION

CHANGE MOTOR DIRECTION

This automatism is a product developed exclusively for the automatic opening of swing gates.

Besides being practical, safe and powerful, this product has a new function incorporated so that you can transform a motor to apply on right leaves to left leaves. This allows greater flexibility in the use of each motor.

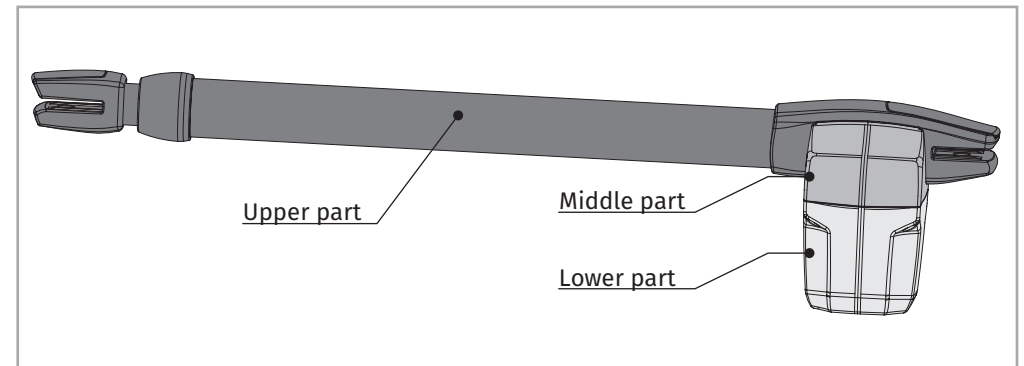

Motor disassembly and assembly process, in order to transform motor, must be done as follows:

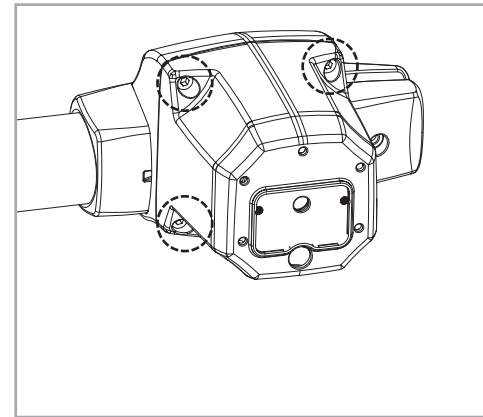

01 • Loosen the 4 screws that fix the Lower Part to Middle Part.

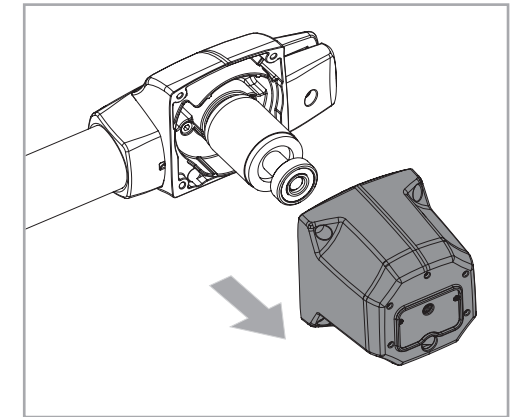

02 • Remove Lower Part.

03. AUTOMATION

CHANGE MOTOR DIRECTION

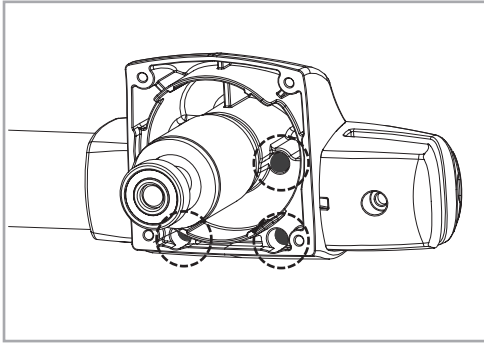

03 • Loosen the 4 screws of the Middle Part.

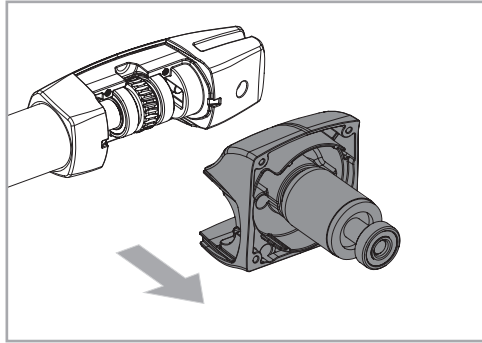

04 • Remove Middle Part.

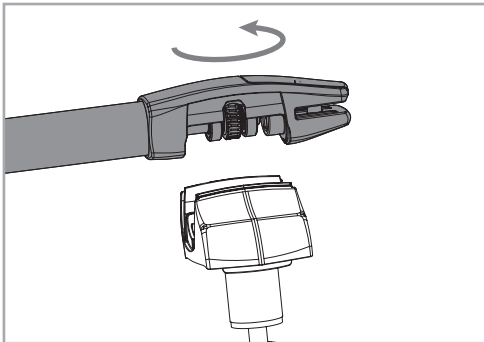

05 • Rotate Upper Part 180°.

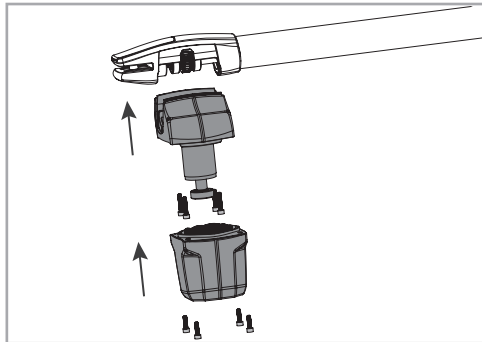

06 • Assemble automation by tightening all components with the screws.

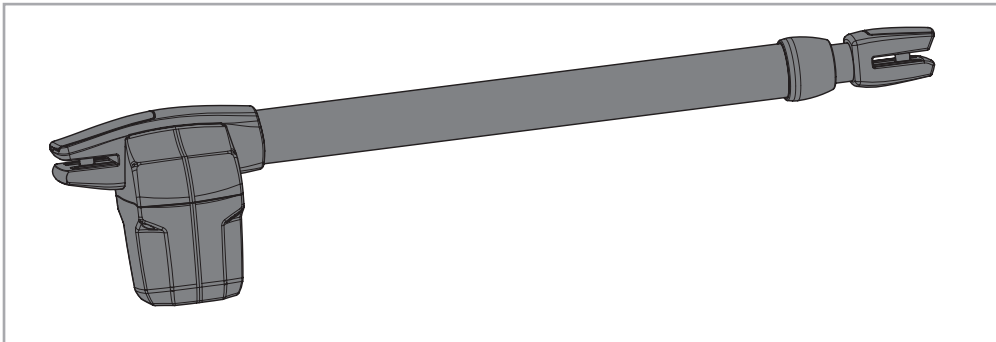

07 • Completely transformed automation.

03. AUTOMATION

MANUAL RELEASE

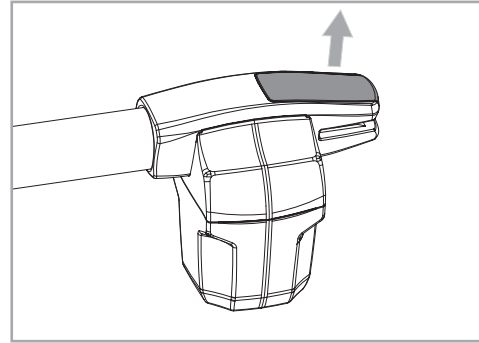

01 • Remove the plastic cover from the back.

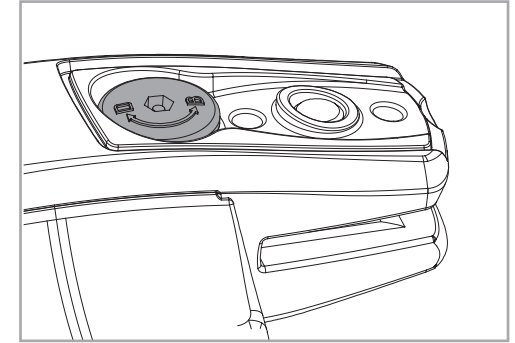

Information engraved on the unlock shaft.
D=Unlock || B=Lock

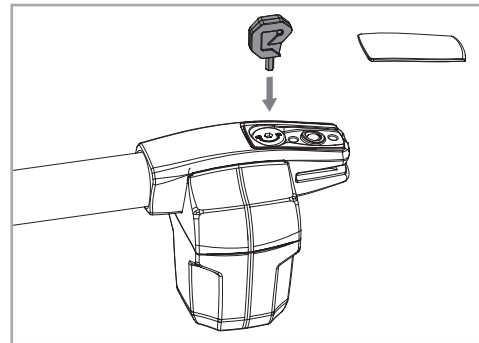

02 • Insert Release key on the unlock shaft.

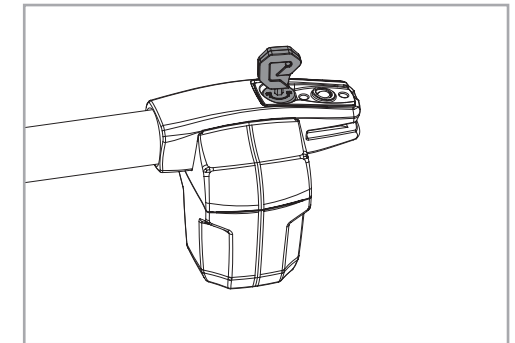

03 • Rotate key 180° in the direction indicated in the figure to unlock.

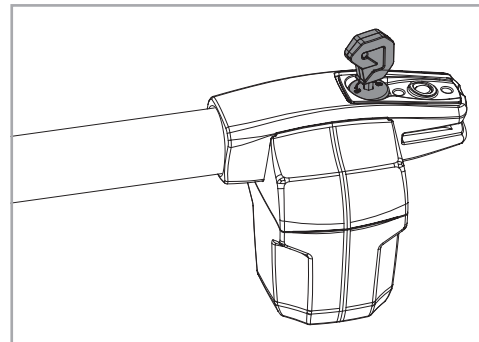

04 • Automation unlocked.

Note • To lock automation so it can work automatically, must do it by turning the key anticlockwise.

03. AUTOMATION

TECHNICAL SPECIFICATIONS

	Model	LINCE300	LINCE400	LINCE600
• Power Supply	230V	230Vac 50/60Hz	230Vac 50/60Hz	230Vac 50/60Hz
	110V	110Vac 50/60Hz	110Vac 50/60Hz	110Vac 50/60Hz
	24V	24Vdc	24Vdc	24Vdc
• Power	230/110V	230W	230W	230W
	24V	60W	60W	60W
• Current	230V	1,3A	1,3A	1,3A
	110V	2,5A	2,5A	2,5A
	24V	1A to 3A	1A to 3A	1A to 3A
• Rotational speed	230/110V	1400 RPM	1400 RPM	1400 RPM
	24V	1600 RPM	1600 RPM	1600 RPM
• Noise level		LpA <= 50 dB (A)	LpA <= 50 dB (A)	LpA <= 50 dB (A)
• Force		2300N	2300N	2300N
• Operating temperature		-25°C to 65°C	-25°C to 65°C	-25°C to 65°C
• Thermal protection		120°C	120°C	120°C
• Protection class		IP54	IP54	IP54
• Working frequency	230/110V	25%	25%	25%
	24V	55%	55%	55%
• Opening time		8 sec. to 13 sec.	13 sec. to 18 sec.	20 sec. to 28 sec.
• Course		300mm	400mm	600mm
• Max leaf length		2500mm	3000mm	4000mm
• Capacitor	230V	8µF	8µF	8µF
	110V	20µF	20µF	20µF
• Opening speed	230V	20mm/s	20mm/s	20mm/s
	24V	23,5mm/s	23,5mm/s	23,5mm/ss

The dimensions of the automation in the **300 || 400 || 600** versions are as follows:

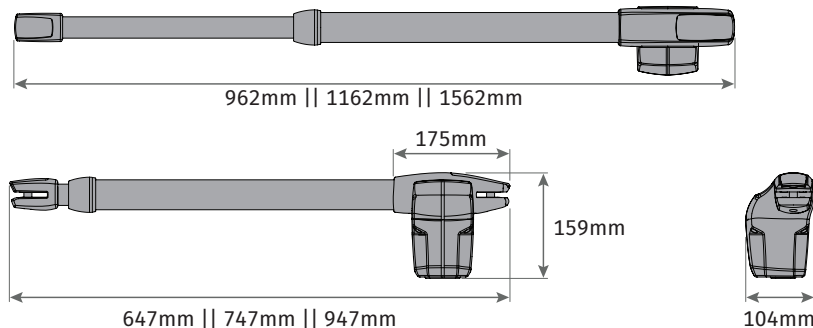

6A

EN

04. INSTALLATION

HEIGHT OF THE SUPPORTS

The automation must be installed with a small inclination, to prevent water infiltration through the extension arm.

For this, the front support must be fixed to the gate with a height lower than the height of the rear support. See example below:

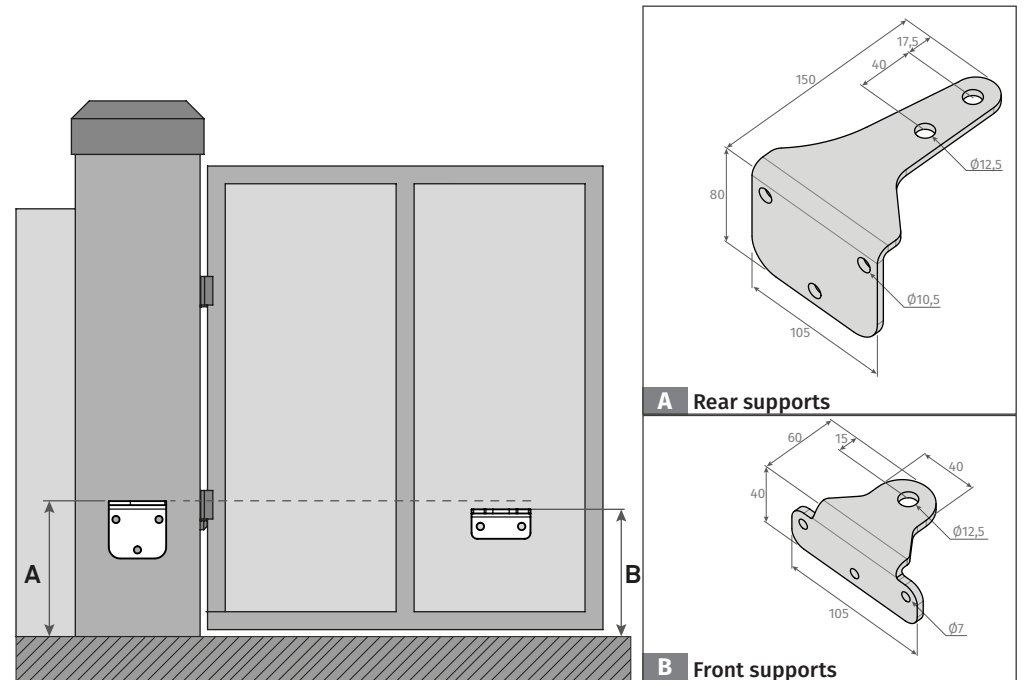

Dimension A • Vertical distance from the floor to the top of the rear support .

Dimension B • Vertical distance from the floor to the top of the c.

A	? mm	It can be any dimension of your choice.
B	A-10mm	10mm below level dimension A.

Example:

If the height of the rear support (**dimension A**) is set at 600mm, then the height of the front support (**dimension B**) will be 590mm (600mm-10mm).



It is very important that these dimensions are respected! Only this way can be assured the correct functioning and durability of the automation!
It is also very important to have a levelled ground/terrain!

EN

6B

04. INSTALLATION

INTERIOR OPENING INSTALLATION DIMENSIONS

In the diagrams illustrated below and on the next page, the **dimensions for the installation** of automations are defined.

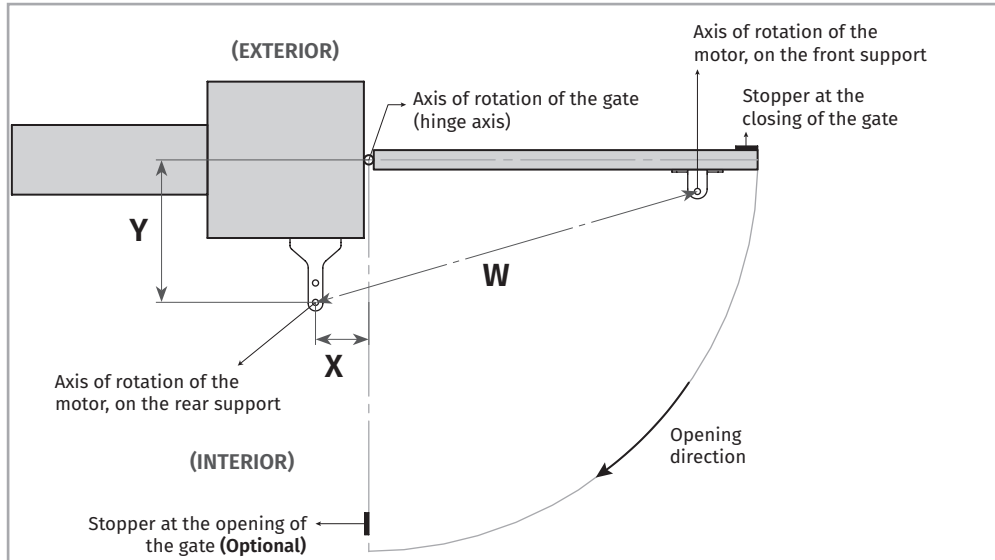

LEGEND

Dimension X	Horizontal distance between hinge axis of the gate and the rear axle of the motor.
Dimension Y	Vertical distance between hinge axis of the gate and the rear axle of the motor.
Dimension W	Distance between axis of the motor supports.

i When installing the automation, it is mandatory to respect the dimensions x and y, indicated in the tables. Within this area, it is possible to identify the maximum opening angle that the gate reaches in these dimensions.

X, Y and W shown in (mm)

! **It is very important that these dimensions are respected!** Only this way can be assured the correct functioning and durability of the automation!

300 (W: 895 ~ 900)			
Y	X		
		140	150
140	98°	94°	91°
150	94°	91°	
160	90°		

400 (W: 1095 ~ 1100)							
Y	X						
		170	180	190	200	210	220
170	108°	107°	103°	100°	97°	95°	93°
180	108°	103°	100°	97°	95°	93°	91°
190	103°	99°	96°	94°	92°	90°	
200	99°	96°	93°	91°			
210	95°	92°	90°				
220	92°						

600 (W: 1494 ~ 1500)																
Y	X															
		200	210	220	230	240	250	260	270	280	290	300	320	340	360	380
220	105°	107°	110°	112°	114°	116°	118°	119°	114°	111°	108°	104°	101°	98°	96°	95°
230	105°	107°	109°	111°	113°	115°	117°	115°	111°	109°	106°	102°	99°	97°	95°	93°
240	104°	106°	109°	111°	113°	115°	116°	112°	109°	106°	104°	100°	98°	95°	93°	92°
250	104°	106°	108°	110°	112°	114°	112°	109°	106°	104°	102°	98°	96°	94°	92°	91°
260	104°	106°	108°	110°	112°	113°	109°	106°	103°	101°	100°	97°	94°	92°	91°	
270	103°	105°	107°	109°	111°	109°	106°	103°	101°	99°	97°	95°	93°	91°		
280	103°	105°	107°	109°	110°	106°	103°	101°	99°	97°	96°	93°	91°			
290	103°	105°	107°	108°	106°	103°	100°	98°	96°	95°	94°	91°				
300	103°	104°	106°	106°	103°	100°	98°	96°	94°	93°	92°					
320	102°	104°	102°	99°	97°	95°	93°	92°	90°							
340	102°	98°	96°	93°	92°	90°										
360	94°	92°	90°													

04. INSTALLATION

EXTERNAL OPENING INSTALLATION DIMENSIONS

In the diagrams illustrated below and on the next page, the **dimensions for the installation of automations** are defined.

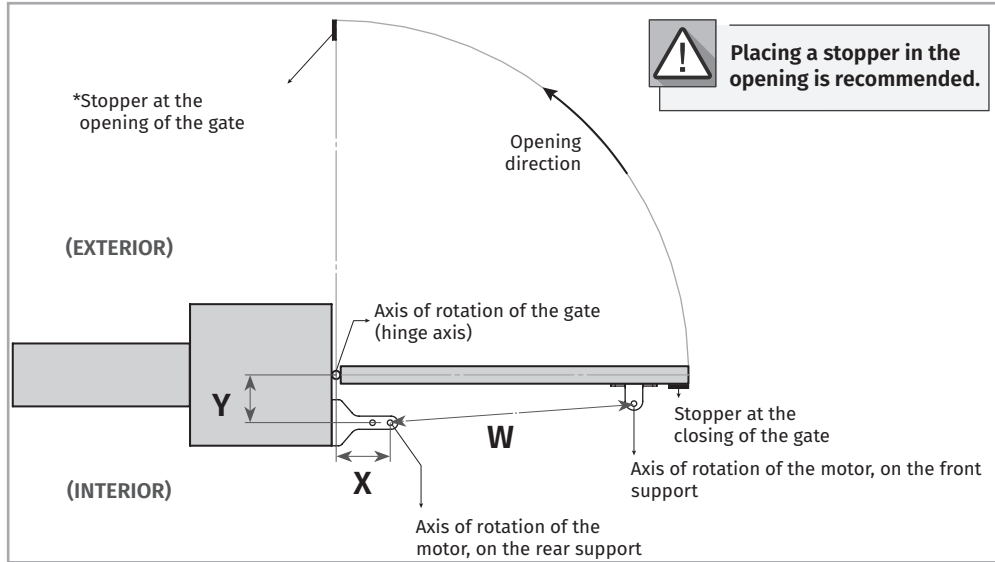

LEGEND

Dimension X	Horizontal distance between hinge axis of the gate and the rear axle of the motor.
Dimension Y	Vertical distance between hinge axis of the gate and the rear axle of the motor.
Dimension W	Distance between axis of the motor supports.

i When installing the automation, it is mandatory to respect the dimensions x and y, indicated in the tables. Within this area, it is possible to identify the maximum opening angle that the gate reaches in these dimensions.

X, Y and W shown in (mm)

! **It is very important that these dimensions are respected!** Only this way can be assured the correct functioning and durability of the automation!

300 (W: 595 - 600)			
Y	X		
	150	160	170
120	95°	97°	92°
130	95°	93°	
140	94°		
150	90°		

400 (W: 695 - 700)							
Y	X						
	170	180	190	200	210	220	230
150	97°	99°	102°	104°	101°	97°	93°
160	96°	99°	101°	103°	98°	94°	91°
170	95°	98°	100°	100°	95°	92°	
180	95°	97°	100°	97°	93°		
190	94°	97°	99°	94°	90°		
200	94°	96°	96°	91°			
210	94°	96°	93°				
220	93°	94°					
230	93°	94°					

600 (W: 900 - 905)														
Y	X													
	200	210	220	230	240	250	260	270	280	290	300	320	340	360
200	96°	99°	101°	102°	104°	106°	108°	109°	111°	112°	114°	105°	99°	93°
210	96°	98°	100°	102°	104°	105°	107°	108°	110°	112°	111°	103°	97°	92°
220	96°	98°	99°	101°	103°	105°	106°	108°	109°	111°	109°	101°	95°	90°
230	95°	97°	99°	101°	102°	104°	106°	107°	109°	110°	107°	99°	93°	
240	95°	97°	98°	100°	102°	104°	105°	107°	108°	109°	104°	97°	92°	
250	94°	96°	98°	100°	101°	103°	105°	106°	107°	106°	102°	96°	90°	
260	94°	96°	98°	99°	101°	102°	104°	105°	107°	104°	100°	94°		
270	94°	96°	97°	99°	100°	102°	103°	105°	105°	102°	98°	92°		
280	94°	95°	97°	98°	100°	101°	103°	104°	104°	100°	96°	90°		
290	93°	95°	97°	98°	100°	101°	102°	104°	102°	98°	94°			
300	93°	95°	96°	98°	99°	101°	102°	103°	99°	96°	93°			
320	92°	94°	96°	97°	98°	100°	101°	99°	95°	92°				
340	92°	94°	95°	97°	98°	99°	99°	95°	92°					
360	92°	93°	95°	96°	97°	99°	95°	91°						
380	92°	93°	94°	96°	97°	95°	91°							
400	92°	93°	94°	95°	95°	91°								

04. INSTALLATION

INSTALLATION STEPS



Pay attention to installation dimensions mentioned on pages 6B, 7 and 8!



It is important to respect this installation order!

Otherwise, it is not possible to ensure correct installation and automation may not work properly!

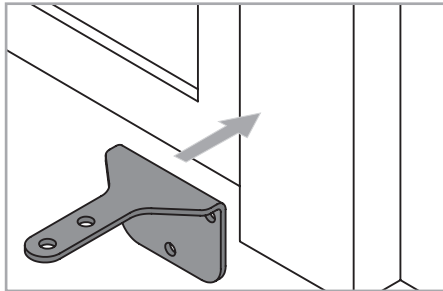

01 • Fix rear support

- The **Rear support** must be fixed to the pillar or wall using dimensions provided in the previous pages. It can be fixed using screws with mechanical bushing or chemical welding process, or one of your choice since that provides proper fixation of the support.

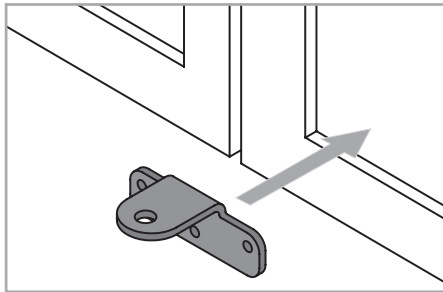

02 • Fix front support

- The **Front support** should be fixed to the gate, respecting height dimensions and distance to the rear support. This may be fixed by using screws, welding process, or another one of your choice, as long as it provides a proper fixation of the support.

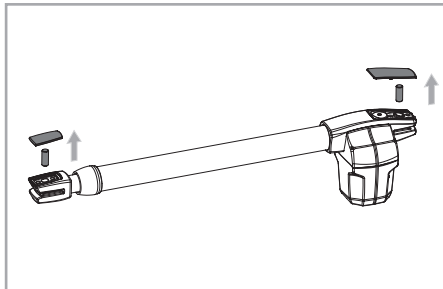

03 • Remove covers and dowels from motor

- Before installing motor, remove covers and dowels from motor.
- At the end of the installation, put back plastic covers for a better visual finish of the automation.

04. INSTALLATION

INSTALLATION STEPS

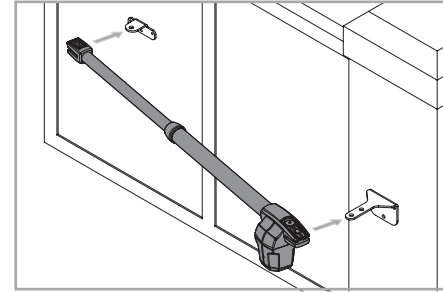

04 • Install automation on the supports

- The automation must be placed on both supports at the same time to avoid leaving the automation suspended by only one of the supports. To make the task easier, you should unlock the automation in order to be able to extend/retract arm easily (see page 5B), to get the correct position for supports.

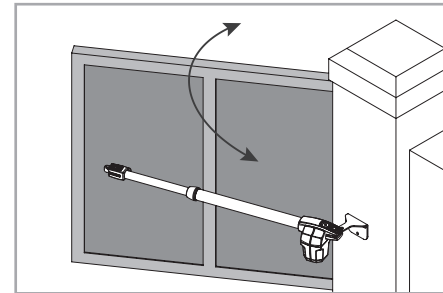

05 • Test movement

- Install the dowels removed earlier on each place with a small amount of lubricant for less friction.
- Move the gate by hand to check that the gate opens and closes without any hindrance. This will ensure that automation is not subjected to problems during operation.

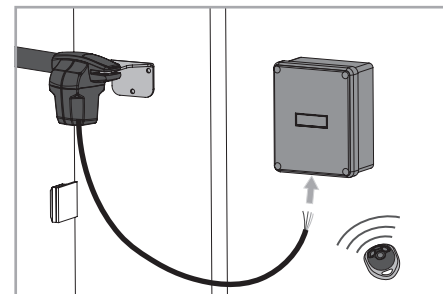

06 • Connecting automation to control board and configuring control devices.

- With the automation installed, connect it to control board for system configuration (see control board user manual). Must also configure the desired control devices (remote controls, push button, etc.) and other additional components such as antenna, flashing lamp, key selector, among others.



SECURITY NOTICE

At the end of the installation, insulate all the holes for passing the cables, to prevent the entry of animals and parasites.

Otherwise, it may jeopardize the proper functioning of the equipment.

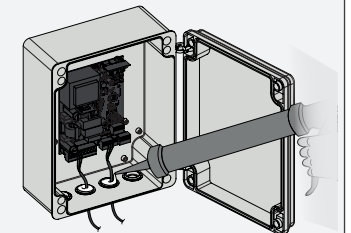

04. INSTALLATION

INSTALLATION MAP

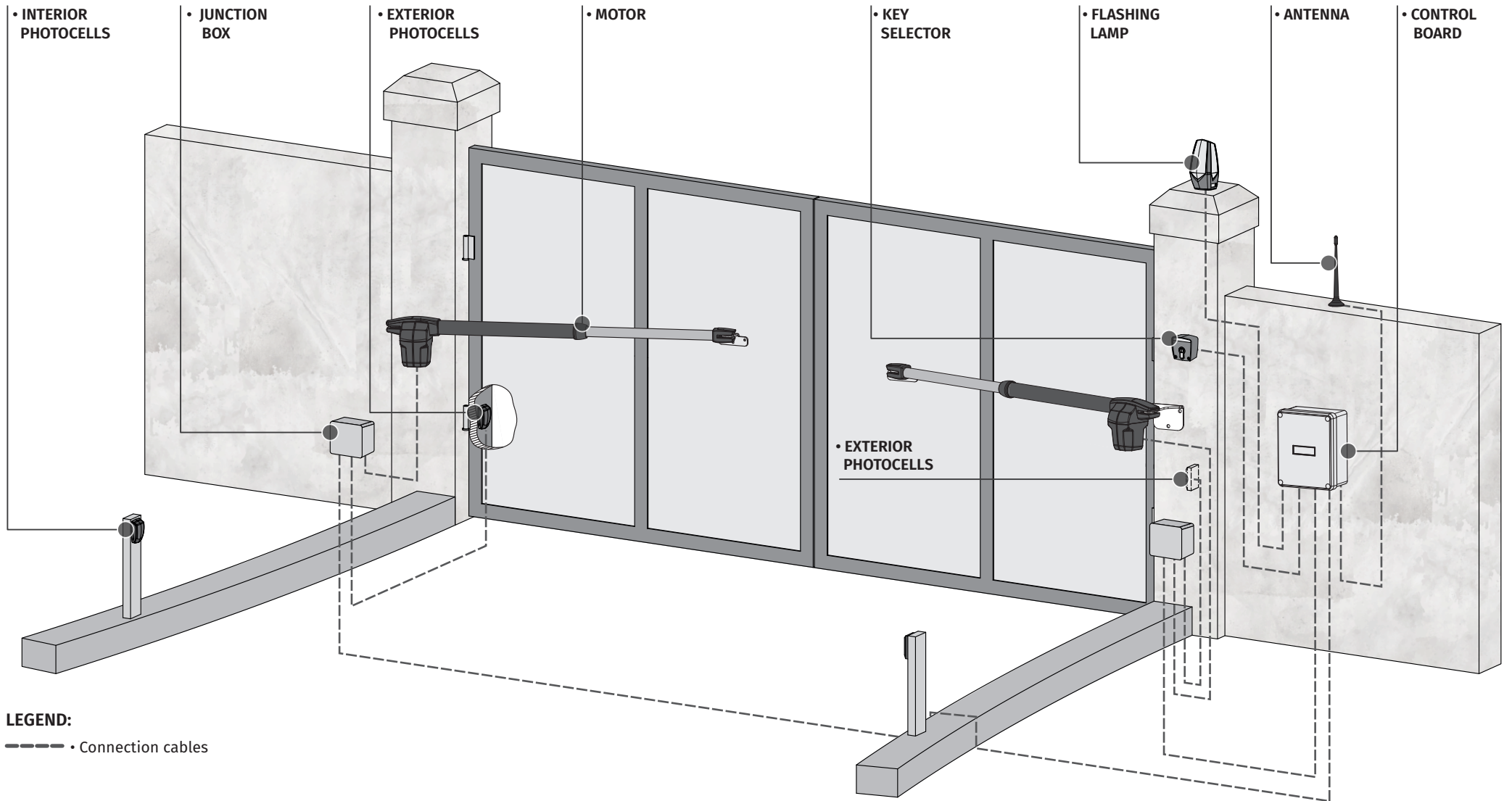

LEGEND:

- - - - • Connection cables



It is important to use stoppers at the opening and closing of the gate. If not respected, components of the automation may suffer efforts for which they were not prepared, and as a result will be damaged.



It is important to use junction boxes for connections between motors, components and control board. All cables must enter and exit on the bottom of the junction and control board boxes.

05. TROUBLESHOOTING

FINAL CONSUMERS INSTRUCTIONS

INSTRUCTIONS FOR SPECIALIZED INSTALLERS

Anomaly	Procedure	Behavior	Procedure II	Discovering the origin of the problem
• Motor doesn't work	• Make sure you have power in the automation control board and if it is working properly.	• Still not working	• Consult a qualified MOTORLINE technician.	<ol style="list-style-type: none"> 1 • Open control board and check if it has 230V/110V/24V power supply; 2 • Check input fuses; 3 • Disconnect motors from control board and test them by connecting directly to power supply in order to find out if they have problems (see page 12A/12B). 4 • If the motors work, the problem is on the control board. Consult the control board manual; 5 • If the motors doesn't work, remove them from installation site and send to our MOTORLINE technical services for diagnosis.
• Motor doesn't move but makes noise	• Unlock motor and move gate by hand to check for mechanical problems on the gate.	• Is the gate stuck?	• Consult an experienced gate expert	<ol style="list-style-type: none"> 1 • Check all motion axis and associated motion systems related with gate and automation (dowels, hinges, etc.) to find out what is the problem.
		• Gate moves easily?	• Consult a qualified MOTORLINE technician.	<ol style="list-style-type: none"> 1 • Check capacitors, testing automation with new capacitors; 2 • If capacitors are not the problem, disconnect motors from control board and test them by connecting directly to power supply in order to find out if they have problems (see page 12A/12B). 3 • If the motors work, the problem is in control board. Pull it out and send it to our MOTORLINE technical services for diagnosis; 4 • If the motors doesn't work, remove them from installation site and send to our MOTORLINE technical services for diagnosis.
• Motor opens but doesn't close	• Unlock motor and move gate by hand to closed position. Lock motor(s) again and turn off power supply for 5 seconds. Reconnect it and send order to open gate using remote control.	• Gate opened but didn't close again.	<ol style="list-style-type: none"> 1 • Check if there is any obstacle in front of the photocells; 2 • Check if any of the control devices (key selector, push button, video intercom, etc.) of the gate are stuck and sending permanent signal to control board; 3 • Consult a qualified MOTORLINE technician. 	<p>All MOTORLINE control boards have LEDs that easily allow to conclude which devices are with anomalies. All safety devices LEDs (LE/LA) in normal situations remain On. All "START" circuits LEDs (LO/LS) in normal situations remain Off. If LEDs devices are not all On, there is some security systems malfunction (photocells, safety edges), etc. If "START" circuits LEDs are turn On, there is a control device sending permanent signal.</p> <p>A) SECURITY SYSTEMS:</p> <ol style="list-style-type: none"> 1 • Close with a shunt all safety systems on the control board (check manual of the control board). If the automated system starts working normally check which device is problematic. 2 • Remove one shunt at a time until you find the malfunction device . 3 • Replace it for a functional device and check if the automation works correctly with all the other devices. If you find another one defective, follow the same steps until you find all the problems. <p>B) START SYSTEMS:</p> <ol style="list-style-type: none"> 1 • Disconnect all wires connected to the START connector. 2 • If the LED turned Off, try reconnecting one device at a time until you find the defective device. <p>NOTE: In case procedures described in sections A) and B) don't result, remove control board and send to our technical services for diagnosis.</p>
• Motor doesn't make complete route	• Unlock motor and move gate by hand to check for mechanical problems on the gate.	• Encountered problems?	• Consult an experienced gate expert	<ol style="list-style-type: none"> 1 • Check all motion axis and associated motion systems related with gate and automation (dowels, hinges, etc.) to find out what is the problem.
		• Gate moves easily?	• Consult a qualified MOTORLINE technician.	<ol style="list-style-type: none"> 1 • Check capacitors, testing with new capacitors; 2 • If capacitors are not the problem, disconnect motors from control board and test them by connecting directly to power supply in order to find out if they are faulty; 3 • If the motors doesn't work, remove them from installation site and send to our MOTORLINE technical services for diagnosis. 4 • If motors work well and move gate at full force during the entire course, the problem is in the control board. Set force on the control board. Make a new working time programming, giving sufficient time for opening and closing with appropriate force (see manual of the control board). 5 • If this doesn't work, remove control board and send it to MOTORLINE technical services services. <p>NOTE: Setting force of the control board should be enough to open and close the gate without stopping, but should stop with a little effort from a person. In case of safety systems failure, the gate can never cause physical damage to obstacles (vehicles, people, etc.).</p>

06. COMPONENTS TEST

230V/110V MOTOR

To detect if the malfunction is on the control board or on the motor is, sometimes, necessary to perform tests with direct connection to a 110V/230V power supply.

For this, it is necessary to intercalate a capacitor on the connection in order to the automatism to work (check the type of capacitor to be used in the product manual). The diagram below, shows how to make that connection and how to intercalate the different components wires.



NOTES:

- To perform the tests, there is no need to remove the automatism from the place it is installed, because in this way, it is possible to understand if the automatism can function properly connected directly to the power.
- You should use a new capacitor during this test to ensure that the problem is not with the capacitor.

- 1 Connect the power wires to the terminal, as shown below.
- 2 Connect the automatism wires in the terminal, intercalate a capacitor in the opening and closing wires.
- 3 Once these connections are completed, connect to a 110V/230V power plug, depending on the motor/control board in test.

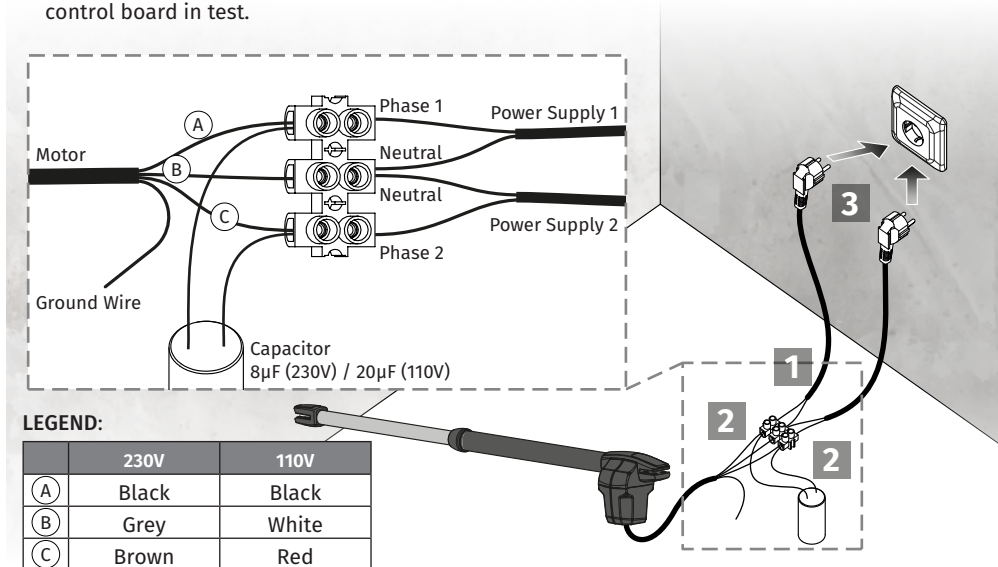

All tests must be performed by specialized technicians due to serious danger associated with the bad use of electrical systems!

06. COMPONENTS TEST

24V MOTOR

To detect which are the components with problems in a 24V automatism installation, it's sometimes necessary to run a test directly to a external power supply (24V battery).

The diagram below shows how to make this connection.

NOTES:

- To make these tests it isn't necessary to remove it from the location where it is installed, because in this way, you can understand if the automation connected directly to the external battery is able to work correctly.
- Once you connect the wires to a battery 24V, the motor must work for one direction. To test the opposite movement, change the position of the wires connected to the battery.

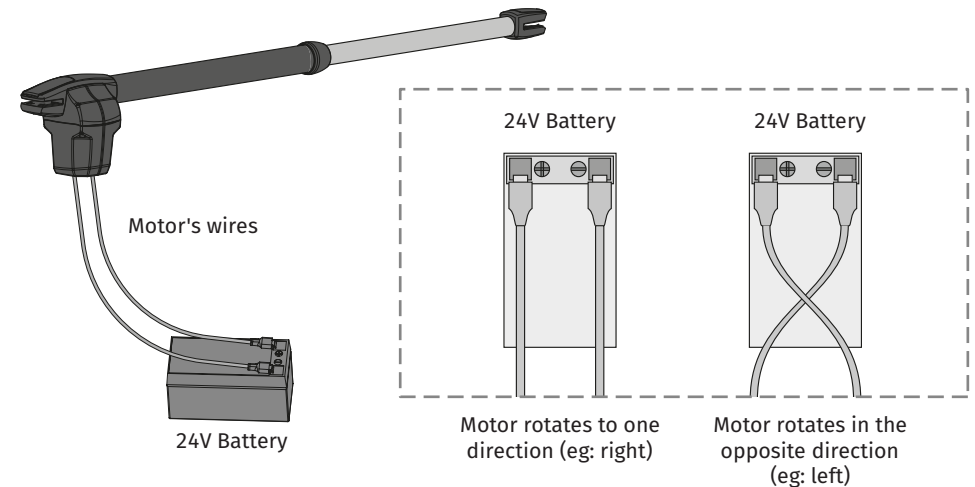

All tests must be performed by specialized technicians due to serious danger associated with the bad use of electrical systems!

07. MAINTENANCE

MAINTENANCE

CLEAN THE TUBE

- With a cloth soaked in lubricant spray, clean all the residues that accumulate in the automation tube.
- Apply a small amount of lubricant spray on the tube and using a dry cloth remove the excess, leaving an even layer on the tube.

LUBRICATE DOWELS

- Remove front and rear covers
- Place a small amount of lubricant on the holes that contains support dowels.
- Install covers on the respective holders.

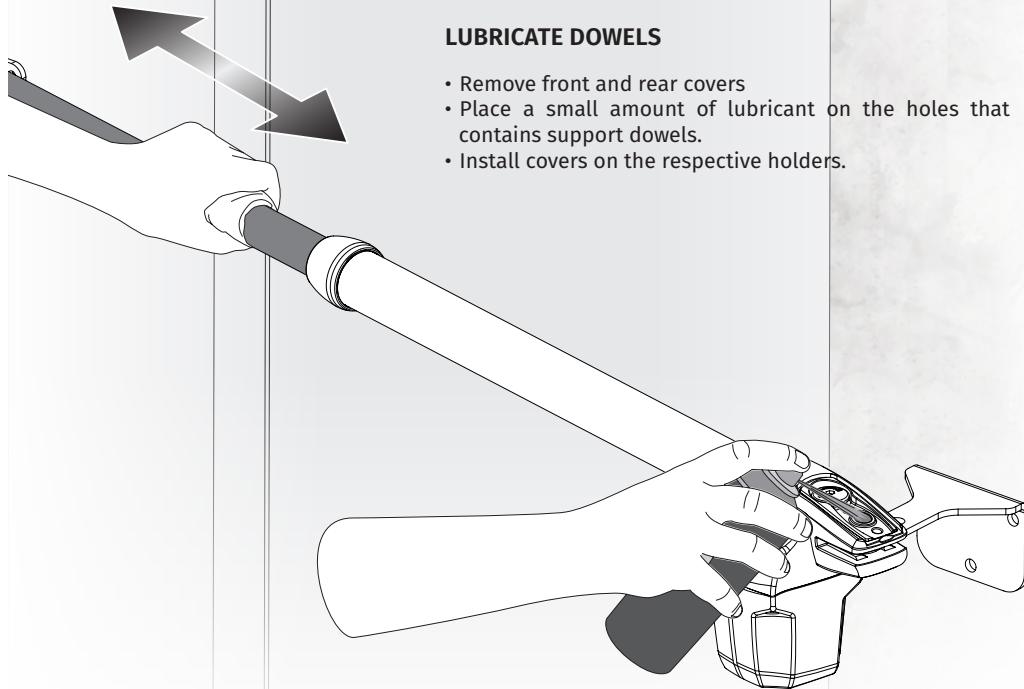

CHECK MOTOR SUPPORTS

- Make sure that supports remain well fixed on the pillars and gate to ensure proper functioning of the equipment.

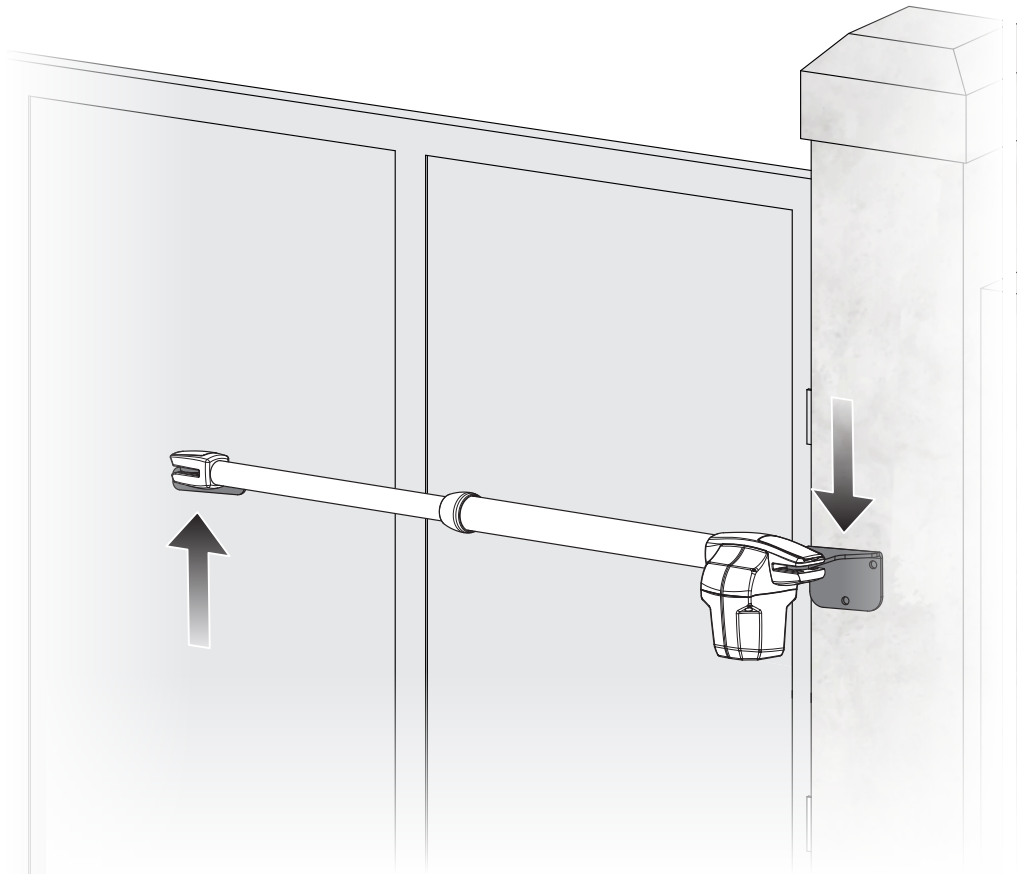

These maintenance measures must be applied every year in order to insure proper functioning of the automation.